



HC49U/49UT Crystals

■ Holder Type: 9U / 9T / 9D / 6A

Frequency Range:

1.8432MHz to 700.00MHz

Features:

- High Reliability & Low Cost Unit
- Tight Stability & Extended Temperature Available
- Lead-free Type

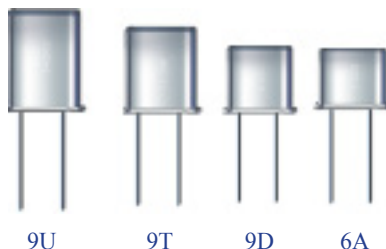

QUARTZ
CRYSTALS

■ Standard Specifications

Item	Value
Frequency Range	1.8432 to 700.00 MHz
Frequency Tolerance @ 25 °C	±30ppm (tighter tolerance also available)
Frequency Tolerance over Temperature Range	±50ppm (tighter tolerance also available)
Operating Temperature Range	-10 °C to +60 °C (other operating range also available)
Operable Temperature Range	-40 °C to +85 °C
Equivalent Series Resistance (ESR)	Please refer to the ESR Table
Drive Level	50µW Typ. (300µW Max.)
Load Capacitance	12pF (3pF, 4.5pF, 6pF and series also available)
Ageing	±5ppm/year

■ ESR Table

Frequency Range (MHz)	Mode	Standard ESR (Ohm)
1.8432 to 2.4	AT Cut Fund.	550
2.4 to 3.0	AT Cut Fund.	300
3.0 to 3.5	AT Cut Fund.	150
3.5 to 4.0	AT Cut Fund.	100
4.0 to 5.5	AT Cut Fund.	80
5.5 to 6.0	AT Cut Fund.	60
6.0 to 8.0	AT Cut Fund.	50
8.0 to 11.0	AT Cut Fund.	40
11.0 to 13.0	AT Cut Fund.	35
13.0 to 16.0	AT Cut Fund.	30
16.0 to 50.0	AT Cut Fund.	25
27.0 to 100.0	BT Cut	30
26.0 to 100.0	3rd Overtone	40
100.0 to 500.0	5rd Overtone	100
100.0 to 700.0	7rd Overtone	150

<http://www.hongkongcrystal.com>
 E-mail: China: sales.cn@hongkongcrystal.com
 HongKong/Overseas: inquiry@hongkongcrystal.com

HongKong/Overseas
 Shenzhen: T:+86

TELCONA

TELCONA AG • Im Vorderasp 4 • CH-8154 Oberglatt • Switzerland
 Tel. +41 (0) 44 860 25 50 • Fax +41 (0) 44 860 28 22
info@telcona.com • www.telcona.com

■ Dimensions (mm)



TOP VIEW



FRONT VIEW

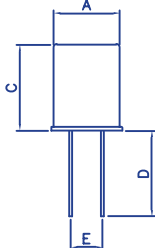

SIDE VIEW

ITEM	DIMENSION	
A	10.16 Max.	
B	3.81 Max.	
C	9U	13.21 Max.
	9T	11.5 Max.
	9D	9.5 Max.
	6A	6.5 Max.
D	1.LEAD LENGTH 13.2±0.5mm(STANDARD)	
	2.LEAD LENGTH (2.8~16)±0.5mm REFER TO CUSTOMER REQUEST	
E	4.88 ±0.2	
F	0.45 ±0.05	
G	11.05 Max.	
H	4.7 Max	

MARKING INFORMATION



XXXXXX = CRYSTAL FREQUENCY

YYYYYY - 2~7 DIGITS TRACEABILITY CODE

■ Bulk pack / Optional Tape Packing(mm)

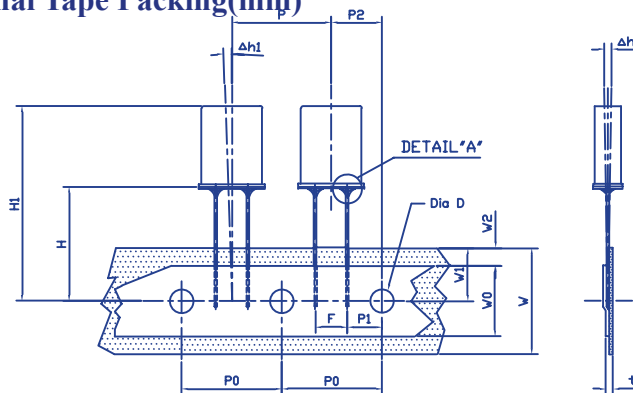

NOTE: CRYSTAL DIMENSIONS PLEASE REFER TO CRYSTAL DRAWING

ITEM	SYMBOL	SIZE (mm)	REMARKS
PITCH OF COMPONENT	P	12.70 ± 1.0	
FEED HOLE PITCH	P0	12.70 ± 0.3	
HOLE CENTER TO LEAD	P1	3.85 ± 0.7	
FEED HOLE CENTER TO COMPONENT CENTER	P2	6.35 ± 0.7	
LEAD TO LEAD DISTANCE	F	5.00 ± 0.5	
COMPONENT ALIGNMENT	Δh	0.00 ± 2.0	
	Δh1	0.00 ± 2.0	
TAPE WIDTH	W	18.00 ± 0.3	
HOLD DOWN TAPE WIDTH	W0	12.00	
HOLD POSITION	W1	9.00 ± 0.5	
HOLD DOWN TAPE POSITION	W2	0.00 ± 0.3	
HEIGHT OF COMPONENT FROM TAPE CENTER	H	16.00 ± 0.3	
LEAD WIRE CLUNCH HEIGHT	HD	32.25 MAX.	
COMPONENT HEIGHT	H1	4.00 ± 0.2	
FEED HOLE DIAMETER	Dia D	0.60 ± 0.3	
TOTAL TAPE THICKNESS	t	1.20 ~ 1.80	
	J	1.20 ~ 1.80	

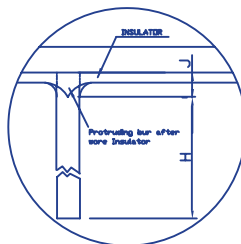

DETAIL 'A'