



#### Frequency Range:

3.01MHz to 100.00MHz

#### Features:

- High Reliability & Low Cost Unit
- Tight Stability & Extended Temperature Available
- Lead-free Type

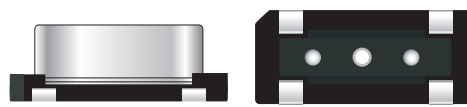

Actual Size

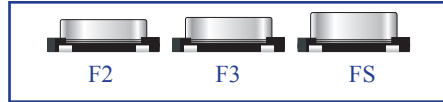

QUARTZ CRYSTALS

### ■ Standard Specifications

Item	Value
Frequency Range <sup>[*]</sup>	3.01 to 100.00 MHz
Frequency Tolerance	±30ppm (tighter tolerance also available)
Frequency Tolerance over Temperature range	±50ppm (tighter tolerance also available)
Operating Temperature Range	-10 °C to +60 °C (other operating range also available)
Operable Temperature Range	-40 °C to +85 °C
Equivalent Series Resistance (ESR)	Please refer to the ESR Table
Drive Level	50µW Typ. (300µW Max.)
Load Capacitance	12pF (3pF, 4.5pF, 6pF and series also available)
Ageing	±5ppm/year

Remark [\*]: F2 package starts from 6.0MHz

### ■ ESR Table

Frequency Range (MHz)	Mode	Standard ESR (Ohm)
3.01 to 3.5	AT Cut Fund.	300
3.5 to 4.0	AT Cut Fund.	150
4.0 to 4.5	AT Cut Fund.	130
4.5 to 5.0	AT Cut Fund.	110
5.0 to 6.0	AT Cut Fund.	80
6.0 to 7.0	AT Cut Fund.	60
7.0 to 10.0	AT Cut Fund.	50
10.0 to 13.0	AT Cut Fund.	40
13.0 to 50.0	AT Cut Fund.	30
27.0 to 100.0	BT Cut	40
26.0 to 100.0	3rd Overtone	100

#### Note:

1. Manufacturer reserves the right to change the specification and content of this product for improvement without notification.
2. Custom specification is welcome. Please contact our sales representative for further details.
3. If the crystal is intended for applications which have direct impact on human life and properties, and require a high degree of reliability and safety concerns, customers must provide full information such as but not limit to the application, electrical and reliability specification at the inquiry beginning stage.
4. Customers have to agree to the "Guideline for handling crystal units" and "Standard Terms and Condition of Sales" which is printed this catalog before placing orders to our company or our distributors. There are also unpredictable factors such as applied condition, oscillation margin and etc and customers must check them beforehand. In case of queries, please do not fail to send inquiry to our company before ordering.

<http://www.hongkongcrystal.com>  
 E-mail: China: [sales.cn@hongkongcrystal.com](mailto:sales.cn@hongkongcrystal.com)  
 HongKong/Overseas: [inquiry@hongkongcrystal.com](mailto:inquiry@hongkongcrystal.com)

HongKong/Overseas  
 Shenzhen: T: +86



TELCONA AG • Im Vorderasp 4 • CH-8154 Oberglatt • Switzerland  
 Tel. +41 (0) 44 860 25 50 • Fax +41 (0) 44 860 28 22  
[info@telcona.com](mailto:info@telcona.com) • [www.telcona.com](http://www.telcona.com)



### ■ Dimensions (mm) and Solder Pad Layout (mm)

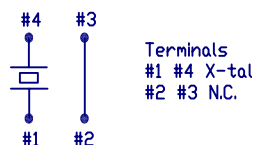
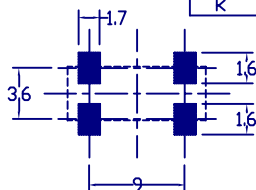
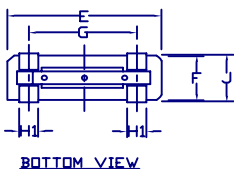
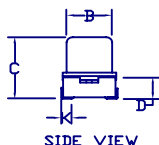
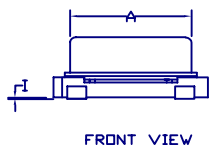
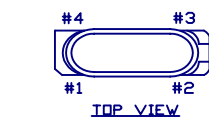

ITEM	DIMENSION	
A	10.16 Max.	
B	3.8 Max.	
C	XTAL TAPE	
	F2	4.2 Max.
	F3	4.5 Max.
	FS	5.5 Max.
D	2.05 Max.	
E	13.1 Max.	
F	4.6 Max.	
G	9	
H1	1.3	
I	0.1±0.1	
J	5.0 Max.	
K	1.0	

#### MARKING INFORMATION

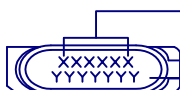

XXXXXX = CRYSTAL FREQUENCY

YYYYYY - 2~7 DIGITS TRACEABILITY CODE

\*MARKING ORIENTATION IS FOR REFERENCE ONLY

### ■ Tape & Reel (mm)

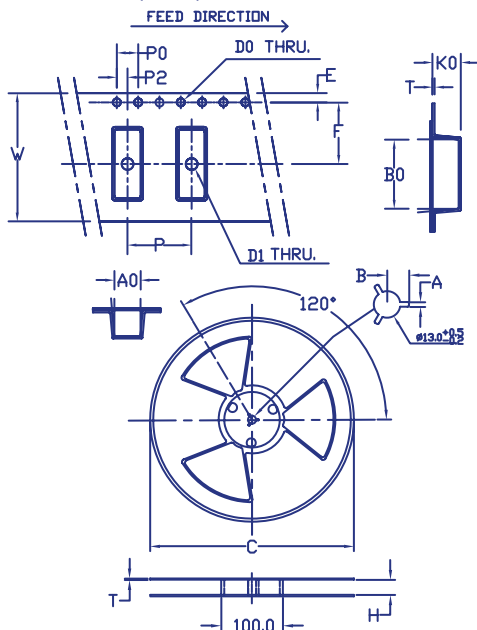

T A P E		F2 F3	FS
	PART NO.	48060037	48060038
W	24.0±0.3	24.0±0.3	
P	12.0±0.1	12.0±0.1	
P2	2.0±0.1	2.0±0.1	
P0	4.0±0.1	4.0±0.1	
A0	5.7±0.1	5.6±0.1	
B0	13.4±0.1	13.4±0.1	
E	1.75±0.1	1.75±0.1	
F	11.5±0.1	11.5±0.1	
D0	Ø1.5±0.1	Ø1.5±0.1	
D1	Ø1.5±0.1	Ø1.5±0.1	
T	0.35±0.05	0.40±0.05	
K0	4.2±0.1	5.5±0.1	
R E E L	PART NO.	48060006	
	C1	Ø330±1	
	A	2.3±0.3	
	B	10.75±0.2	
	T	24.5±0.1	
	H	2.3±0.3	
QTY.	1000PCS/R		