



## 8X3.8 Plastic SMD Crystals

■ Holder Type: M3

### Frequency Range:

20.00kHz to 75.00kHz

### Features:

- High Reliability & Low Cost Unit
- Tight Stability & Extended Temperature Available
- RoHS Compliant
- 260°C Reflow Compatible



Actual Size



## ■ Standard Specifications

Item	Value	
Frequency Range	32.768kHz	20.0~75.0kHz
Equivalent Series Resistance (ESR)	50kΩ Max	55kΩ Max
Frequency Tolerance @ 25 °C	±20ppm (tighter tolerance also available)	
Temperature Coefficient	-0.034±0.006ppm /°C <sup>2</sup>	
Operating Temperature Range	-40 °C to +85 °C (other operating range also available)	
Operable Temperature Range	-55 °C to +125 °C	
Turnover Temperature	25 °C ± 5 °C	
Load Capacitance	6.0pF , 8.0pF , 12.5pF is standard	
Drive Level	0.1μW Typ. (1.0μW Max.)	
Shunt Capacitance	2.0pF Max	
Ageing	±5ppm/year	

### Note:

1. Manufacturer reserves the right to change the specification and content of this product for improvement without notification.
2. Custom specification is welcome. Please contact our sales representative for further details.
3. If the crystal is intended for applications which have direct impact on human life and properties, and require a high degree of reliability and safety concerns, customers must provide full information such as but not limit to the application, electrical and reliability specification at the inquiry beginning stage.
4. Customers have to agree to the "Guideline for handling crystal units" and "Standard Terms and Condition of Sales" which is printed in this catalog before placing orders to our company or our distributors. There are also unpredictable factors such as applied condition, oscillation margin and etc and customers must check them beforehand. In case of queries, please do not fail to send inquiry to our company before ordering.

<http://www.hongkongcrystal.com>

E-mail: China: [sales.cn@hongkongcrystal.com](mailto:sales.cn@hongkongcrystal.com)

HongKong/Overseas: [inquiry@hongkongcrystal.com](mailto:inquiry@hongkongcrystal.com)

HongKong/Overseas  
Shenzhen: T: +86 755 2610 8888

# TELCONA

TELCONA AG • Im Vorderasp 4 • CH-8154 Oberglatt • Switzerland  
Tel. +41 (0) 44 860 25 50 • Fax +41 (0) 44 860 28 22  
[info@telcona.com](mailto:info@telcona.com) • [www.telcona.com](http://www.telcona.com)

### ■ Dimensions (mm) and Solder Pad Layout (mm)

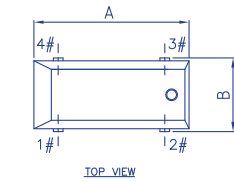

ITEM	DIMENSION
A	8.0 MAX.
B	3.8 MAX.
C	5.5
D	0.5
E	2.5 MAX.
F	(0.9)

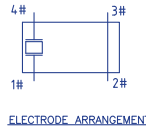
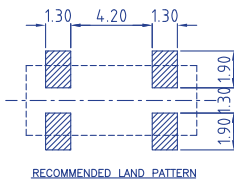
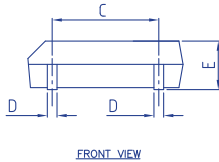

#### MARKING INFORMATION



REMARK: Do not connect #2 and #3 to external circuit or GND (Floating)

### ■ Tape & Reel (mm)

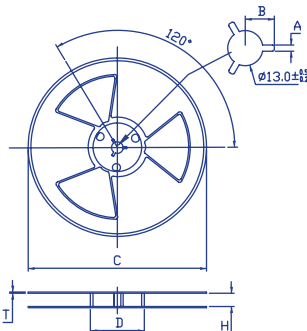
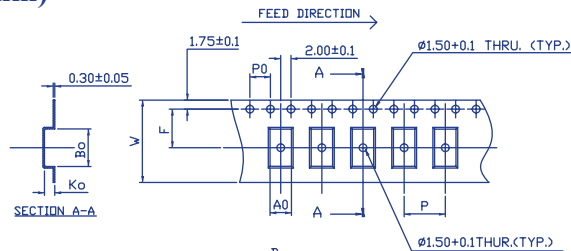

REMARK: (1)CAMBERS DO NOT EXCEED 10MM IN 100MM.  
 (2)THE MAXIMUM CUMULATIVE TOLERANCE IS ±0.2MM FOR 10 SPROCKET HOLE PITCH.  
 (3)THICKNESS OF CARRIER TAPE IS 0.3MM.

MATERIAL: TRANSPARENT ANTI-STATIC POLYSTYRENE

M3		
T A P E	PART NO.	48065017
	W	16.00±0.3
	P	8.00±0.1
	A0	4.10±0.1
	B0	8.45±0.1
	K0	2.70±0.1
	P0	4.00±0.1
R E E L	PART NO.	48060050
	C	φ330.0±1
	A	2.3±0.3
	B	10.75±0.2
	H	16.5±0.3
QTY.		3000 PCS/R